

**NEW  
6.2 DIESEL  
POWER**

# '82 CHEVY SUBURBAN



**CHEVY IS THE POWER  
IN TRUCKS.**

## **SUPER NEWS: NEW DIESEL POWER FOR THE SUPERWAGON.**

Announcing a new economical diesel engine for Chevy Suburban. For 1982 Chevy Suburban is available with a new 6.2 Liter Diesel engine. This engine has been specifically designed for truck use and is rated at 130 SAE net HP. Just the right size for vehicles like the Suburban. And there are no spark plugs, points, coil or condenser to replace. No carburetor to worry about. If like many automotive experts, you're convinced that diesel power is the power of the future, enjoy it today. In a 1982 Chevy Suburban.

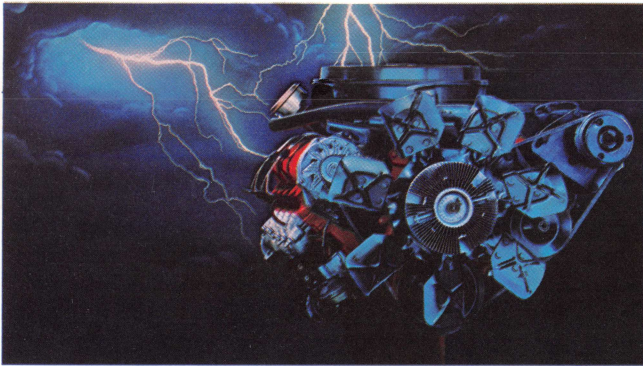

**Chevy Suburban and diesel power. A great trailering combination.** Suburban has long had the reputation as a superb trailer-hauler. And now with new diesel

power available, it's sure to become even more popular when it comes to trailering. A Series C20 Suburban with new 6.2 Liter Diesel and proper equipment can move up to 13,500 lbs. including itself, passengers, cargo and the trailer. Considerably more than you could move with any ordinary wagon.

A weight-distributing hitch platform for trailers up to 9500 lbs. is available through Chevrolet. In addition, Chevrolet offers a wide range of trailering equipment including trailer wiring harness. Optional 31- or 40-gallon fuel tanks are also available.

**Important: A word about this catalog.** We have tried to make this catalog as comprehensive and factual as possible and we hope you find it helpful. However, since the time of printing, some of the information you will find here may have been updated. Also, some of the equipment shown or described throughout this catalog is available as factory-installed options, as dealer accessories and as specialized equipment from various independent suppliers at extra cost. Your dealer has details and, before ordering, you should ask him to bring you up to date.

The right is reserved to make changes at any time, without notice, in prices, colors, materials, equipment, specifications and models. Check with your Chevrolet dealer for complete information.

To obtain EPA fuel economy estimates for Chevrolet light-duty trucks, check the wall poster at your dealer's showroom.

**AMERICA'S GOING DIESEL  
AND CHEVY'S GOT WHAT IT TAKES**





C20 Suburban Silverado shown in Colonial Yellow and Almond

(On cover) C10 Suburban Silverado Diesel shown in Midnight Blue and Light Blue Metallic



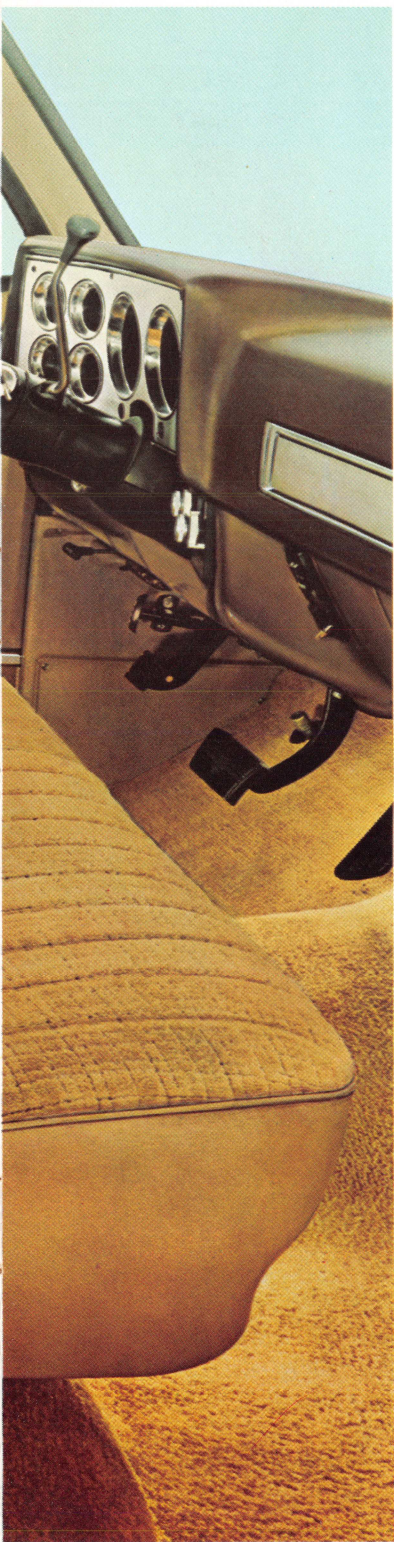

Scottsdale Interior shown in Blue

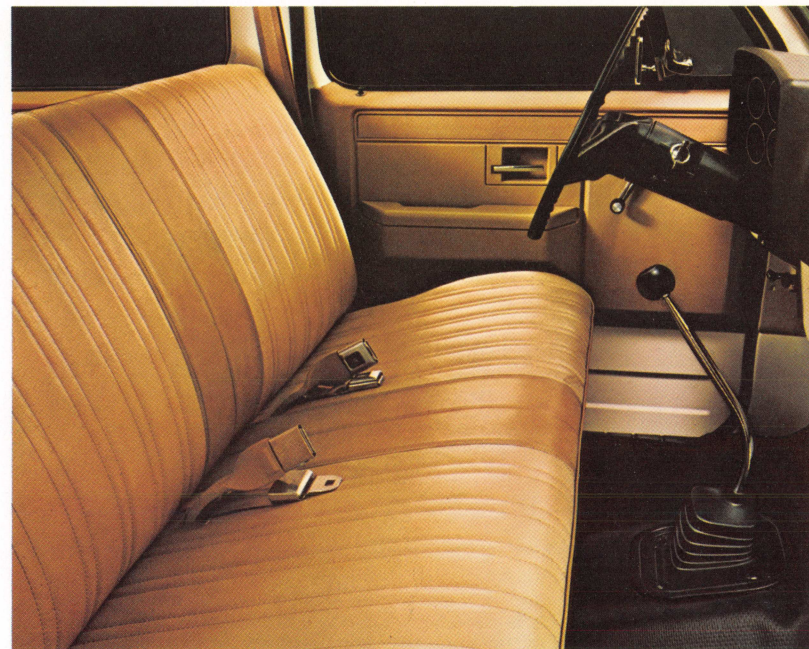

Custom Deluxe Interior shown in Medium Almond

## ROOM. SUBURBAN-STYLE.

**The Silverado interior.** As luxurious as it is big. Here is Suburban's top of the line. The full-depth, foam-cushioned front seat is upholstered in your choice of either cut-pile velour cloth in four colors or leather-grain vinyl in three colors. Deep-pile carpet lies underfoot. While around you are such luxury touches as the custom steering wheel, the handsome instrument panel with bright-brushed instrument cluster frame and needle-type full-gage instrumentation. On the doors, full door-trim panels with brushed aluminum inserts, new cloth appliques, soft vinyl armrests, carpeting on lower portions, and, on front doors only, roomy storage pockets. And there's a visor-mounted mirror on the passenger side. Four interior trim colors match the seat color of your choice.

As shown at left, the Suburban can be equipped to carry nine adults. The optional second seat can be folded down easily and the optional third seat removed to provide a long, flat cargo area. Outside, the Silverado comes with a distinctive chrome-accented grille, dual stacked rectangular headlights, and chrome bumpers, front and rear. Also included are lower body-side moldings, rear moldings and wheel opening moldings.

**The Scottsdale interior.** A comfortable place for a lot of people to be. Includes full-depth, foam-cushioned front seat with handsome embossed two-tone vinyl trim. Custom cut-pile velour cloth upholstery and leather-grain custom vinyl seat trim are available options. Full-length, color-keyed insulated headliner included. Custom vinyl trim shown. Exterior appointments include front and rear chrome bumpers, bright-trimmed black body-side and rear door or tailgate moldings and bright window moldings.

**The Custom Deluxe interior.** All this and more comes standard. Features include full-depth, foam-cushioned front seat with embossed vinyl trim; cockpit-type instrument cluster; color-keyed plastic door trim panels; padded sun visors; tip-out ashtray and glove box; front compartment lamp and black full-length rubber floor mat.

Exterior trim includes grille outline moldings, bright right and left outside mirrors, side and rear drip moldings and bright hubcaps.



K20 Suburban Silverado shown in Carmine Red  
(Luggage carrier is dealer installed)

## THE ONLY THING HANDIER THAN THE 2WD SUBURBAN: THE 4WD SUBURBAN.

Suburban's rugged 4-wheel-drive system features automatic locking front hubs. When you shift from freewheeling 2WD to 4WD, the hubs automatically lock up, eliminating the need to get out of the cab to set them.

To revert to 2WD, simply stop the vehicle, shift into 2WD, slowly back up about ten feet and go

your way. K10 and K20 models have a lightweight aluminum transfer case with synchronized gears that allow you to shift from 2WD to 4WD at speeds under 25 MPH. The transfer case shift console is floor-mounted with lighted indicator so it's easy to see, day or night.

**Low entry height.** Suburban 4WD models offer you convenient entry height. Only 21.6 to 23.6 inches, depending on the model selected. But even with this low entry height, you still get a solid margin of 7.0 inches ground clearance. Suburban's Front Quad Shock off-road handling option is popular for 4WD applications.

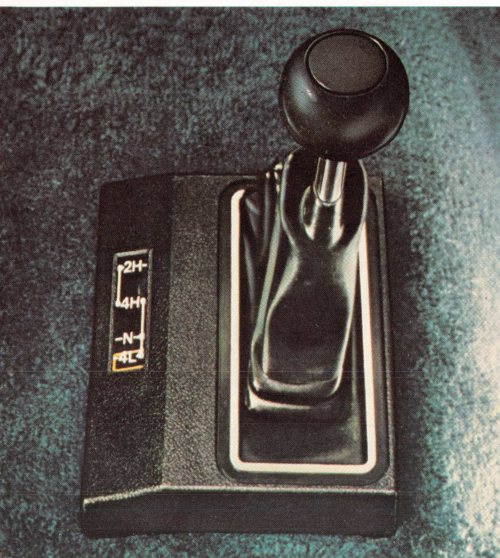

Lighted shift console standard

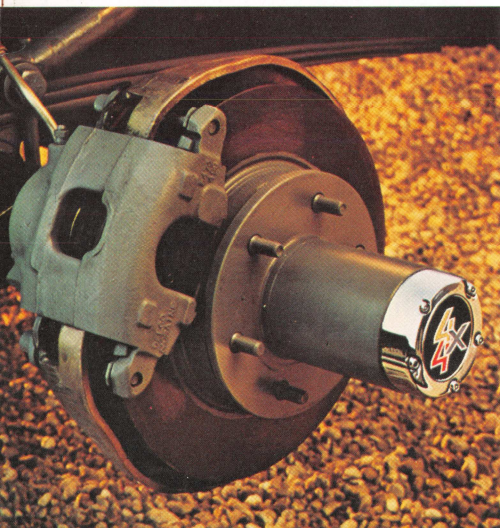

Automatic locking hubs/power brakes std.

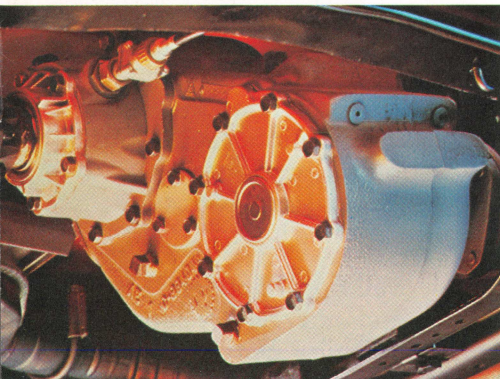

Lightweight 2-speed transfer case

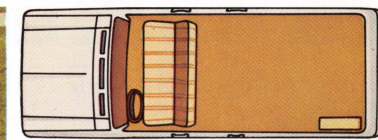
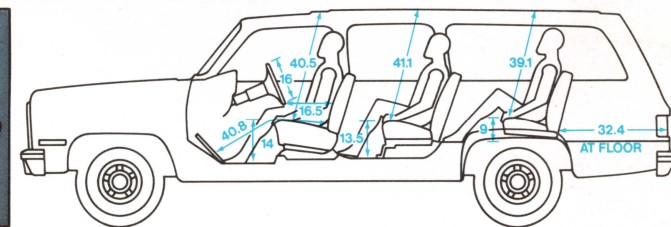
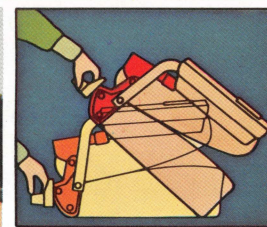

Suburban with standard front seat



Optional second seat added

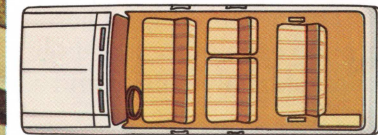

Optional third seat for nine-passenger seating

C20 Suburban shown in Mahogany Metallic and Almond

## THE SUPERWAGON VS. THE ORDINARY WAGON. NO CONTEST.

**Comfortable room for 9 ride-poolers.** You'll find plenty of room inside Chevy Suburban for energy-conserving ride pools. Properly equipped, Suburban is the ideal way to move up to nine people with plenty of leg, shoulder and elbow room all around. Two carloads of people can ride in one Suburban and be very comfortable. And ride-pooling with the new Diesel Suburban just makes all the more sense.

**Large-size inside. Garage-size outside.** And with its tough truck build, Suburban can carry big payloads. Up to 3930 lbs. including people and cargo. The double rear doors open 37.8" high and nearly 60" wide below window to give you easy access to all that cargo area. A wagon-type, bottom-hinged tailgate is

also an available model. Yet with all that room inside, Suburban remains trim enough outside to fit into most residential garages.

**Choose your seating arrangement.** In seconds. The standard front bench seat handles three people comfortably. The optional  $\frac{2}{3}$ - $\frac{1}{3}$  split second seat offers room for three more, and it can be easily folded down to create a cargo deck all the way to the tailgate giving you 144 cu. ft. of load space. With the optional quick-release third seat, Suburban can seat nine adults and still have room for cargo in back. The seat can be removed by releasing latches and sliding it off the front anchors.

# THE NEW 6.2 LITER DIESEL.

This optional V8 engine is all new from the block up. Its size is right—6.2 liters. Its power is right. And during times like these, its economy is right.

There are two versions of this new diesel offered. One for Suburbans up to and including 8500 lbs. GVWR and one for Suburbans over that. Both models feature the proven Ricardo Comet V precombustion chamber design that contributes to high efficiency and impressive emissions control. A block and fuel line heater is standard to aid in cold-weather operation.

The new 6.2 Liter Diesel features five head bolts around each bore, four-bolt main bearing caps, roller hydraulic valve lifters and a forged steel crankshaft.

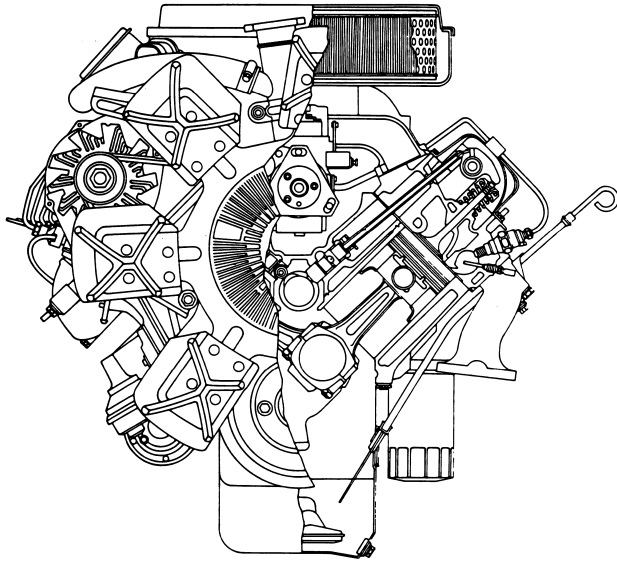

**An anti-moisture system.** To help eliminate the problem in some diesel fuel, a combination fuel-strainer/waste-separator in the tank screens out water and lets it lie at the bottom of the tank. When the water level reaches a point where it could be drawn into the system, a moisture sensor flashes an alarm in the cab. A water drain pipe with a valve near the rear spring allows the water to be siphoned out easily.

**V8 gasoline engines.** Last year Chevrolet introduced a new 5.0 Liter (305 Cu. In.) V8 with Electronic Spark Control, and this highly efficient engine has been widely accepted. It provides surprising acceleration and horsepower for an engine of its size. It has a substantial 9.2-to-1 compression ratio. The engine is designed to run most efficiently on unleaded fuel at maximum

spark advance. A sensor unit is used to detect a “knock” condition, and the Electronic Spark Control unit automatically retards the spark. It’s standard on the Series C10 model. (Not available in California.)

A bigger 5.7 Liter (350 Cu. In.) V8 is available for the C10 Suburban and standard on the C20 model. A 7.4 Liter (454 Cu. In.) V8 is optional for the C20 model. On K10 and K20 (4WD) Suburbans the 5.7 Liter (350 Cu. In.) V8 is standard.

**New 4-speed automatic transmission with overdrive.** This new automatic features a fourth gear overdrive ratio that decreases engine speed by 30% on the highway. Coupled with a higher numerical axle ratio, this provides impressive performance in low and intermediate driving ranges.

This automatic overdrive transmission is standard on all C10 models and optional on K10 models. A 4-speed manual transmission is standard on C20 and K10-20 models. A 3-speed automatic is optional on all C-K20 models.

Please refer to Suburban power team engine information below.

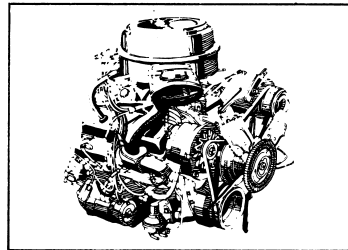

7.4 Liter (454 Cu. In.) V8

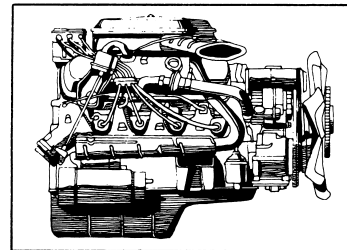

5.0 Liter (305 Cu. In.) V8 with ESC

	ENGINES WITH LT./MEDIUM-DUTY EMISSIONS FOR MODELS OF 8500 GVWR AND BELOW FOR ALL STATES			ENGINES WITH HEAVY-DUTY EMISSIONS FOR MODELS OVER 8500 GVWR FOR ALL STATES		
DISPLACEMENT—LITER (Cu. In.)	5.0L (305) V8*†	5.7W (350) V8	6.2L V8 Diesel	5.7 (350) V8	7.4L (454) V8	6.2L V8 Diesel
ENGINE ORDERING CODE	LE9(B)	LS9(A)	LH6(A)	LT9(A)	LE8(A)	LL4(A)
BORE & STROKE	3.74 x 3.48	4.0 x 3.5	3.98 x 3.80	4.0 x 3.5	4.3 x 4.0	3.98 x 3.80
COMPRESSION RATIO	9.2 to 1	8.2 to 1	21.5 to 1	8.3 to 1	7.9 to 1	21.5 to 1
SAE NET HORSEPOWER @ RPM	160 @ 4400	165 @ 3800	130 @ 3600	(a) 160 @ 3800 (b) 155 @ 4000	210 @ 3800	N.A.
SAE NET TORQUE (lb.-ft.) @ RPM	235 @ 2000	275 @ 1600	240 @ 2000	(a) 250 @ 2800 (b) 240 @ 2800	340 @ 2800	N.A.

(A) Produced by GM—Chevrolet Motor Division

(B) Produced by GM—Chevrolet Motor Division and GM of Canada

N.A.—Not Available at time of publication (a) 49-state ratings

†Not Available in California

\*Electronic Spark Control

(b) California ratings

# RUGGEDNESS IS SPELLED S-U-B-U-R-B-A-N.

**A. Strong Truck Frame.** Deep-section, steel side rails for strength. The side rail drop-center design allows low body mounting for easy entry and exit.

**B. Low-drag Front Disc Brake Calipers.** To reduce rolling resistance from the brakes.

**C. Rugged Girder Beam Front Suspension.** A steel girder beam is the major component of the rugged suspension on 2-wheel-drive Suburbans.

**D. Aluminized Muffler.** Outer shell and interior baffles are heavy-gage metal, aluminized inside and out to help fight corrosion.

**E. Computer-matched Brake System.** Power-assisted front disc brakes and finned rear drum brakes are computer-matched to the gross vehicle weight rating of the Suburban you order.

**F. Finned Rear Brake Drums.** Cast iron-steel rear brake drums are finned to promote cooling. Outer edges are curved to help keep contaminants from lining.

**G. Two-stage Multi-leaf Rear Springs.** Provide good ride with light loads. Progressively firmer support as cargo weight increases. They're treated with special anti-corrosive paint.

**H. Double-wall Front Fenders.** One-piece inner and outer fender panels for structural rigidity. Both steel panels are Zincrometal.<sup>®</sup>



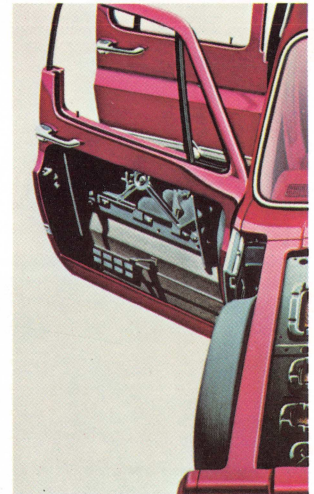
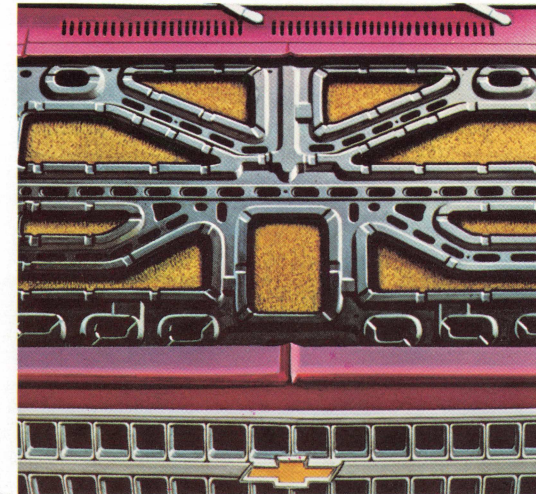
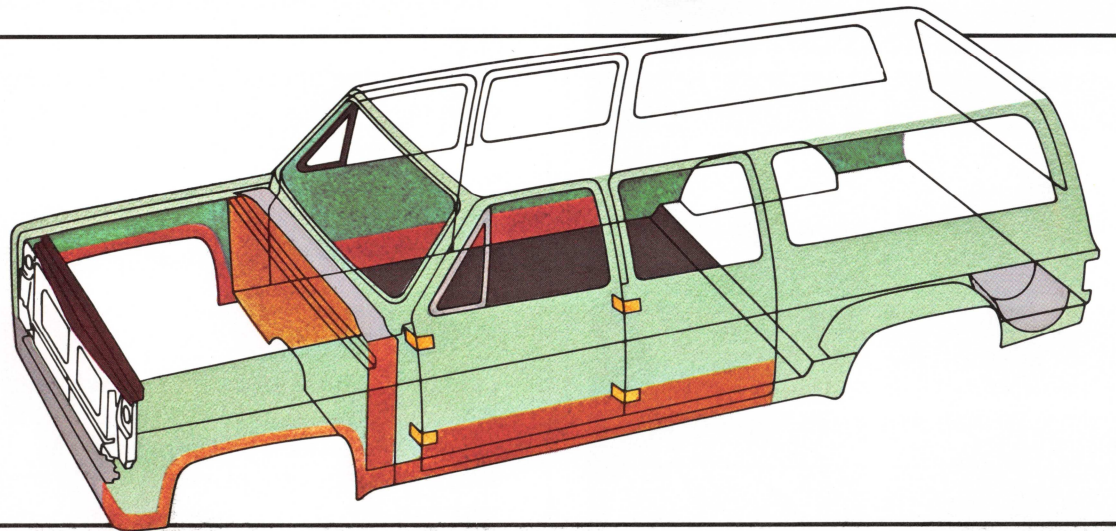
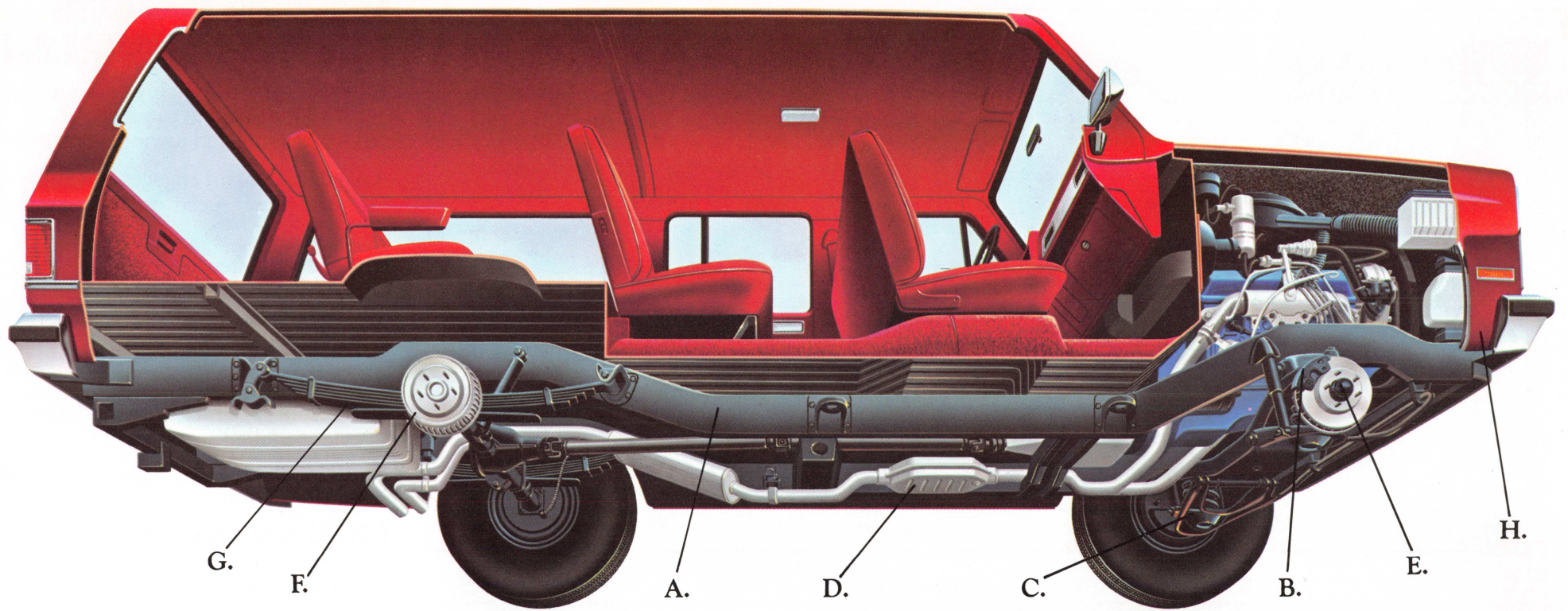

■ **Zincrometal® galvanized steel** □ **ELPO primer**. Electrical charging helps draw paint into hidden seams and crevices for added corrosion protection of entire body, doors and tailgate ■ **Aluminum-wax application**. Inside rocker panels, door and fender bottoms. ■ **Galvanized steel**. Besides areas shown here, it is used in window sashes and rear window channel ■ **Zinc-plated steel**. Sidedoor hinges ■ **Zinc iron alloy coated steel**. Radiator and grille upper panel reinforcement.

- **Underhood Insulation**. Standard on Silverado models. Helps absorb engine sounds.
- **Double-paneled Hood**. Fabricated of two pieces of steel welded together for torsional rigidity. Outer panel is corrosion-resistant Zincrometal.
- **Double-wall Doors**. Add rigidity. Both steel panels are Zincrometal.

## POPULAR OPTIONS FOR YOUR SUBURBAN

A wide range of available options lets you outfit your Suburban to your specific riding, carrying and towing requirements.

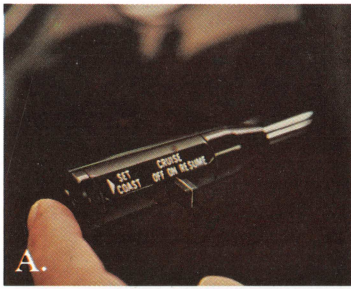

A.

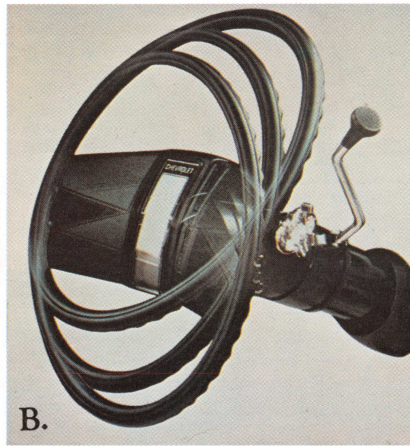

B.

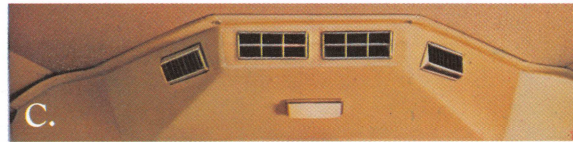

C.



D.

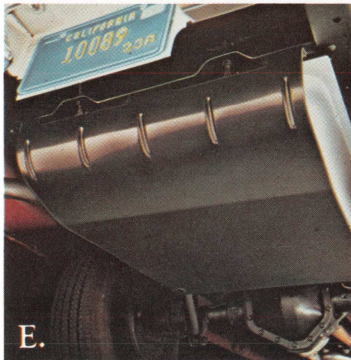

E.

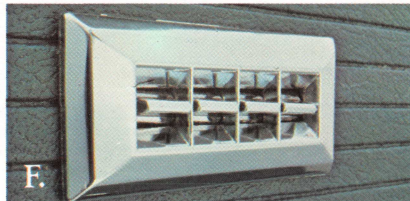

F.

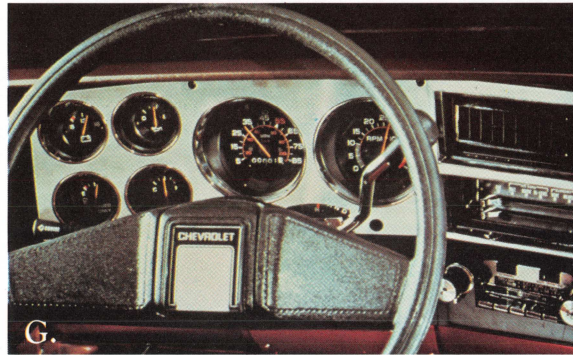

G.

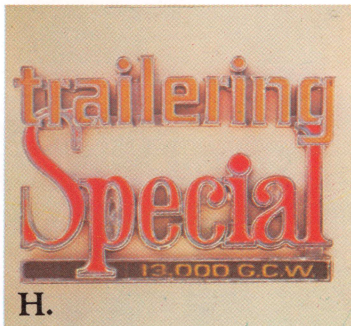

H.

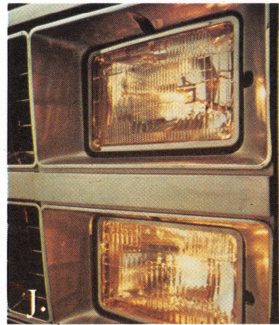
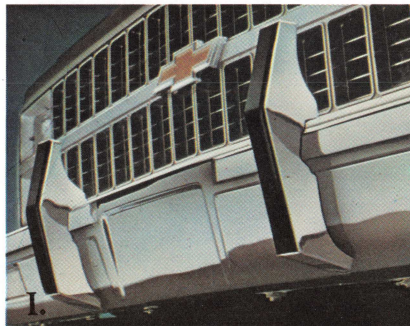

J.

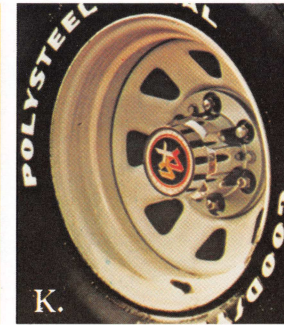

K.



L.



M.

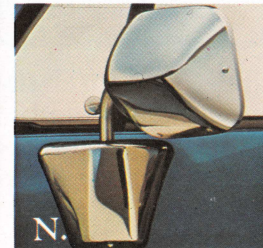

N.



O.



P.

**A. Cruise Control** engages at a touch to maintain preset speed. Includes Resume Speed feature.

**B. Comfortilt steering wheel.** Select any one of six different positions for your driving comfort.

**C. Dual-unit front and rear air conditioning.**

**D. Roof luggage rack with air deflector.** (Dealer installed accessory.)

**E. Optional 31- and 40-gallon fuel tanks.** A fuel tank stone shield is also optional.

**F. Power windows** for all side doors. (Also available: power window for tailgate, power door locks for all side doors.)

**G. Gage-type instrument clusters** (standard on Silverado).

**H. Trailering Special Package.** Required equipment varies, depending on gross combination weight. (See chart on back cover.)

**I. Front bumper guards.**

**J. Rectangular halogen headlights** for all models.

**K. Styled wheels.**

**L. Delco radio options** include AM and AM/FM radio, AM/FM stereo. AM/FM stereo with 8-track player or AM/FM stereo with cassette player, AM/FM stereo with CB.

**M. Trailer weight-distributing hitch platform.**

**N. Below Eyeline mirrors.**

**O. Rally wheels.**

**P. Wheel covers.**

Tires supplied by various manufacturers.

# Appearance and Convenience Options

	C10	C20	K10	K20
Air Conditioning, Front	B	B	B	B
Air Conditioning, Front & Rear	B	B	B	B
Bright Metal Wheel Covers	B	B	B	B
Bucket Seats	B	B	B	B
Bumpers:				
Chromed Front Bumper Guards	B	B	B	B
Deluxe Front and Rear	B	B	B	B
Cigarette Lighter	B	B	B	B
Color-Keyed Floor Mats	B	B	B	B
Comfortilt Steering Wheel	B	B	B	B
Deluxe Front Appearance Package	B	B	B	B
Electric Clock w/Quartz Movement	B	B	B	B
Glass, Deep Tinted	B	B	B	B
Halogen Headlamps	B	B	B	B
Heater, Rear	B	B	B	B
Intermittent Windshield Wipers	B	B	B	B

	C10	C20	K10	K20
Mirrors:				
Painted Below Eyeline Mirrors	B	B	B	B
Stainless Steel Below Eyeline Mirrors	B	B	B	B
Stainless Steel Camper Mirrors	B	B	B	B
Moldings:				
Body-Side Moldings—Black	B	B	B	B
Body-Side Moldings—Bright	B	B	B	B
Custom Molding Package—Black	B	B	B	B
Deluxe Molding Package—Bright	B	B	B	B
Door Edge Guards	B	B	B	B
Operating Convenience Package:	B	B	B	B
Power Door Locks	B	B	B	B
Power Windows	B	B	B	B
Paint Options:				
Special Two-Tone Paint	B	B	B	B
Exterior Decor Package	B	B	B	B

	C10	C20	K10	K20
Delco Radios & Accessories:				
AM Radio	B	B	B	B
AM/FM Radio	B	B	B	B
AM/FM Stereo Radio	B	B	B	B
AM/FM Stereo w/8-Track Tape	B	B	B	B
AM/FM Stereo w/Cassette Tape	B	B	B	B
AM/FM Stereo w/CB & Antenna	B	B	B	B
Rear Auxiliary Speaker	B	B	B	B
Windshield Antenna	B	B	B	B
Roof Marker Lamps	B	B	B	B
Seat, 3-Passenger Rear	B	B	B	B
Seat, Folding Center	B	B	B	B
Tailgate, Electric Window	B	B	B	B
Tailgate, Electric Window w/Defogger	B	B	B	B
Wheels, Rally	B			
Wheels, Styled	B			

# Performance and Heavy-Duty Equipment Options

	C10	C20	K10	K20
Air Cleaner Pre-Cleaner (Interim '82)	D	D	D	D
Auxiliary Battery	G	G	G	G
Cold Climate Package	G	G	G	G
Coolers: Engine Oil	G	G	G	G
Transmission Oil	B	B	B	B
Cruise Control	B	B	B	B
Deadweight Trailer Hitch	B	B	B	B
Front Quad Shocks			B	B
Front Stabilizer Bar	G			

	C10	C20	K10	K20
Front Tow Hooks			B	B
Fuel Tank, 31-Gallon (G) 32-Gallon (D)	B	B	B	B
Fuel Tank, 40-Gallon (G) 41-Gallon (D)	B	B	B	B
Fuel Tank, Stone Shield Plate	B	B	B	B
Gages: Volt, Temp. and Oil	B	B	B	B
Generator, 63-Amp	G	G	G	G
Heavy-Duty Battery	G	G	G	G
Heavy-Duty Front & Rear Shocks	B		B	
Heavy-Duty Front Stabilizer		B		

	C10	C20	K10	K20
Heavy-Duty Front Springs			B	B
Heavy-Duty Radiator	G	G	G	G
Locking Rear Axle Differential	B	B	B	B
Power Steering	G	G		
Trailer Wiring Harness, 7-Wire	B	B	B	B
Trailer Special Equipment	B	B	B	B
Weight-Distributing Hitch Platform	B	B	B	B

G = Gas B = Both gas & diesel D = Diesel

A tough record to beat. 94.0% of Chevy Light-, Medium-, Heavy-Duty trucks and commercial vans in the ten most recent years recorded were still on the job. (Based on R. L. Polk & Co. model year registrations through July 1, 1980. 1981 statistics not available at time of printing.)

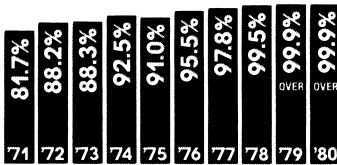

(1971-72-73 DATA PARTLY ESTIMATED.)

**GM Power-Protection-Plus.** See your dealer for details and information about GM's new 24-month/24,000-mile Power-Protection-Plus Limited Warranty.

**GM Continuous Protection Plan.**

An option that offers service protection in addition to that provided by GM's new vehicle limited warranty. Available only in the U.S. and Canada for the 1982 model year. Ask your dealer about this option.

**1982 Chevrolet Three-Year Perforation-From-Corrosion Limited Warranty.** Exhaust system components not included. See your Chevy dealer for details on other limitations.

## A WORD ABOUT ASSEMBLY, COMPONENTS AND OPTIONAL EQUIPMENT IN THESE CHEVROLET PRODUCTS.

The Chevy Suburbans described in this catalog (Series C10, C20, K10 and K20) are assembled at facilities of General Motors Corporation operated by Chevrolet Motor Division.

These Chevys incorporate thousands of different components produced by various divisions of General Motors and by various suppliers to General Motors. From time to time during the manufacturing process, it may be necessary, in order to meet public demand for particular vehicles or equipment, or to meet federally mandated emissions, safety and fuel economy requirements, or for other reasons, to produce these products with different components or differently sourced components than initially scheduled. All such components have been approved for use in these Chevrolet products and will provide the quality performance

associated with the Chevrolet name.

With respect to factory-installed extra cost optional equipment, make certain you specify the type of equipment you desire on your vehicle when ordering it from your dealer. Some options may be unavailable when your vehicle is built. Your dealer receives advice regarding current availability of options. You may ask the dealer for this information. GM also requests the dealer to advise you if an option you ordered is unavailable. We suggest that you verify that your vehicle includes the optional equipment you ordered or, if there are changes, that they are acceptable to you.

These vehicles are also available from GMC dealers under the GMC nameplate (GMC Suburban Series C1500, C2500, K1500 and K2500).

**A WORD ABOUT ENGINES.** Some Chevrolets are equipped with engines produced by other GM divisions, subsidiaries, or affiliated companies worldwide. See your Chevrolet dealer for details.

# Specifications—Suburban Gasoline Engine Models

SERIES	C10 2-WHEEL DRIVE		C20 2-WHEEL DRIVE		K10 4-WHEEL DRIVE		K20 4-WHEEL DRIVE	
	6100 to 6800		8600		6100-6800		8600	
<b>GVW RANGE (LB)</b>	6100 to 6800		8600		6100-6800		8600	
<b>AVAILABILITY</b>	Standard	Optional	Standard	Optional	Standard	Optional	Standard	Optional
<b>ENGINE—LITER (cu. in.)</b>	5.0L (305)#	5.7L (350)	5.7L (350)	7.4L (454)	5.7L (350)	—	5.7L (350)	—
<b>FRONT SUSPENSION</b>	Type/Spring Capacity (lb.)	Independent-Coil Springs 3250	Independent-Coil Springs 3800		Hypoid Driving Axle—Leaf Springs 3600		Leaf Springs 3800	
<b>REAR SUSPENSION</b>	Axle Type Capacity (lb.)	Semi-Floating 3750	Semi-Floating** 6000		Semi-Floating 4000		Semi-Floating 6000	
<b>BRAKES</b>	Disc/Drum	Power	H.D. Power		Power		H.D. Power	
<b>STEERING</b>	Type	Manual	Power		Power		Power	
<b>TRANSMISSION</b>	Manual Automatic	— 4-Spd Automatic/OD	4-Spd. —		4-Spd. —		4-Spd. —	
			▲4-Spd Automatic/OD ◆3-Spd Automatic		4-Spd Automatic/OD		4-Spd Automatic/OD	
<b>TRANSFER CASE—Automatic Locking Front Hubs</b>	—		—		New Process 208		New Process 208	
<b>TIRE SIZE, TUBELESS</b>	P235/75R15		LT235/85R16 D(F) E(R)		P215/75R15		LT235/85R16 D(F) E(R)	

## Diesel Engine Suburban (Require 6.2 Liter Diesel Engine and B3J Diesel Equipment)

<b>ENGINE—LITER (cu. in.)</b>	6.2L (379)	—	6.2L (379)	—	6.2L (379)	—	6.2L (379)	—
<b>FRONT SUSPENSION</b>	Type/Spring Capacity (lb.)	Independent-Coil Springs 3400	Independent-Coil Springs 3800		Hypoid Driving Axle—Leaf Springs 3600		Leaf Springs 3800	
<b>REAR SUSPENSION</b>	Axle Type Capacity (lb.)	Semi-Floating 3750	Semi-Floating 6000		Semi-Floating 4000		Semi-Floating 6000	
<b>BRAKES</b>	Disc/Drum	Power	H.D. Power		Power		H.D. Power	
<b>STEERING</b>	Type	Power	Power		Power		Power	
<b>TRANSMISSION</b>	Automatic	4-Spd Automatic/OD	—		■ 3-Spd Automatic		■ 4-Spd Automatic/OD	
<b>TRANSFER CASE—Automatic Locking Front Hubs</b>	—		—		New Process 208		New Process 208	
<b>TIRE SIZE, TUBELESS</b>	■ P235/75R15XL		LT235/85R16 D(F) E(R)		■ P235/75R15		LT235/85R16 D(F) E(R)	

\*Not Available in California    Tire load range—D (8 PR), E (10 PR)    ▲ Not available with LE8 454 Engine    \*\*Full floating design included with 7.4L 454 engine    ■ Required with 6.2L diesel engine  
#Electronic Spark Control—High Compression Engine    ◆ Available with LE8 454 Engine only    • Larger Size Tubeless Tires Available

## Trailering Special Package Contents and Requirements

	GASOLINE ENGINE MODELS					▲ DIESEL ENGINE MODELS			
	C10	K10	C20	C20	K20	C10	K10	C20	K20
<b>ENGINE</b>	350-4V8	350-4V8	350-4V8 (Std.)	454-4V8	350-4V8 (Std.)	6.2L V8	6.2L V8	6.2L V8	6.2L V8
<b>TRANSMISSION</b>	*Automatic (Std.)	*Automatic	*Automatic	Automatic (Std.)	*Automatic	*4-Spd. Auto.	*4-Spd. Auto.	3-Spd. Auto.	3-Spd. Auto.
<b>REAR AXLE RATIO (:1)</b>	3.73	3.73	4.10	3.73/4.10	4.10	3.73	3.73	4.10	4.10
<b>EQUIPMENT INCLUDED:</b>									
Trailer Hitch Platform	X	X	X	X	X	X	X	X	X
Trailer Wiring Harness, 7-Wire	X	X	X	X	X	X	X	X	X
Engine Oil Cooler	X	X	X	X	X	Standard	Standard	Standard	Standard
Transmission Oil Cooler	X	X	X	X	X	X	X	X	X
Power Steering	X	Standard	X	X	Standard	Standard	Standard	Standard	Standard
H.D. Shocks, Front and Rear	X	—	Standard	Standard	Standard	Standard	Standard	Standard	Standard
H.D. Generator, 63-amp.	X	X	X	X	X	Standard	Standard	Standard	Standard
<b>GCWR SHOWN ON NAMEPLATE†</b>	11,000	11,000	12,000	13,000/15,000	12,000	11,000	11,000	12,000	12,000

†GCWR—Gross combination weight rating    \*4-speed automatic with overdrive    ▲ Requires B3J Diesel Equipment

## Colors



**CHEVY IS THE POWER IN TRUCKS.**